

HVAC Water Systems

Dual Temperature Chilled Water Loops

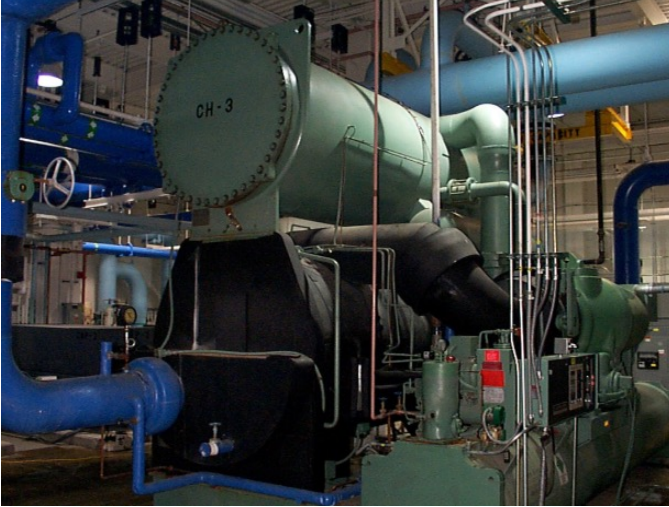

Summary

Chiller energy can account for 10 to 20% of total cleanroom energy use. The majority of annual chilled water use goes to medium temperature chilled water requirements – 55°F for sensible cooling and 60 to 70°F for process cooling loads. When outside air temperatures are cool and humidity is low (i.e., no low-temperature water is needed for dehumidification), 100% of the chilled water is for medium temperature loop uses.

Standard cleanroom chiller plant design provides chilled water at temperatures of 39 to 42°F. While this temperature is needed for dehumidification, the low setpoint imposes an efficiency penalty on the chillers. Typically, heat exchangers and/or mixing loops are used to convert the low temperature, energy intensive chilled water into warmer chilled water temperatures for sensible or process cooling loads.

Chiller efficiency is a function of the chilled water supply temperature. All other things equal, higher chilled water temperatures result in improved chiller efficiency. For example, by dedicating a chiller in a dual chiller plant to provide chilled water at 55°F, 20 to 40% of chiller energy and peak power can be saved when compared to both chillers operating at 42°F.

Table 1. Chiller Efficiency

Chilled Water Supply Temperature	Efficiency
42°F	0.49 kW/ton
60°F	0.31 kW/ton

1. The chiller efficiency reported is based on manufacturer's simulated data of the same chiller. The water-cooled chiller was simulated running at 100% full load and had a condenser water supply temperature 70°F in both cases.

Principles

- Chiller work is proportional to the vapor pressure work of the compressor – this work is lowered if chilled water temperatures are raised and/or condenser water temperatures are lowered. (See *Control of Chilled Water Systems* best practices).
- Because of less compressor work, medium temperature chillers have smaller compressors and are thus lower in cost on a dollars per ton and electrical infrastructure basis as compared to chillers delivering standard lower chilled water temperatures.
- The majority of cleanroom chilled water requirements are best served by medium temperature, 55 to 70°F chilled water.

Approach

Cleanroom facilities usually have a number of medium temperature loops required by the industrial processes. Recirculation cooling may be supplied by coils that use mixing stations to supply a non-condensing 55°F water temperature and a process cooling water loop would utilize a heat-exchanger to create water between 60 and 70°F. Energy savings are realized not by creating medium temperature demands, but by designing a system that creates medium temperature water directly without wasting energy intensive low temperature water.

Cleanroom facilities typically need low temperature water only to handle peak outside air loads. Peak loads by definition occur 2 to 5% of the time in a year. For example, an outdoor air drybulb (DB) temperature of 95°F is used for design conditions, but 24-hour operating conditions may be at an average outside air temperature of 70°F DB. Typically, make up air conditioning accounts for 25–30% of the chilled water load, while recirculation air and process cooling loads account for 60–70%. See Figure 1.

Figure 1. Comparison of Design versus Actual Operating Chilled Water Loads for a 13,000 sf Cleanroom Facility

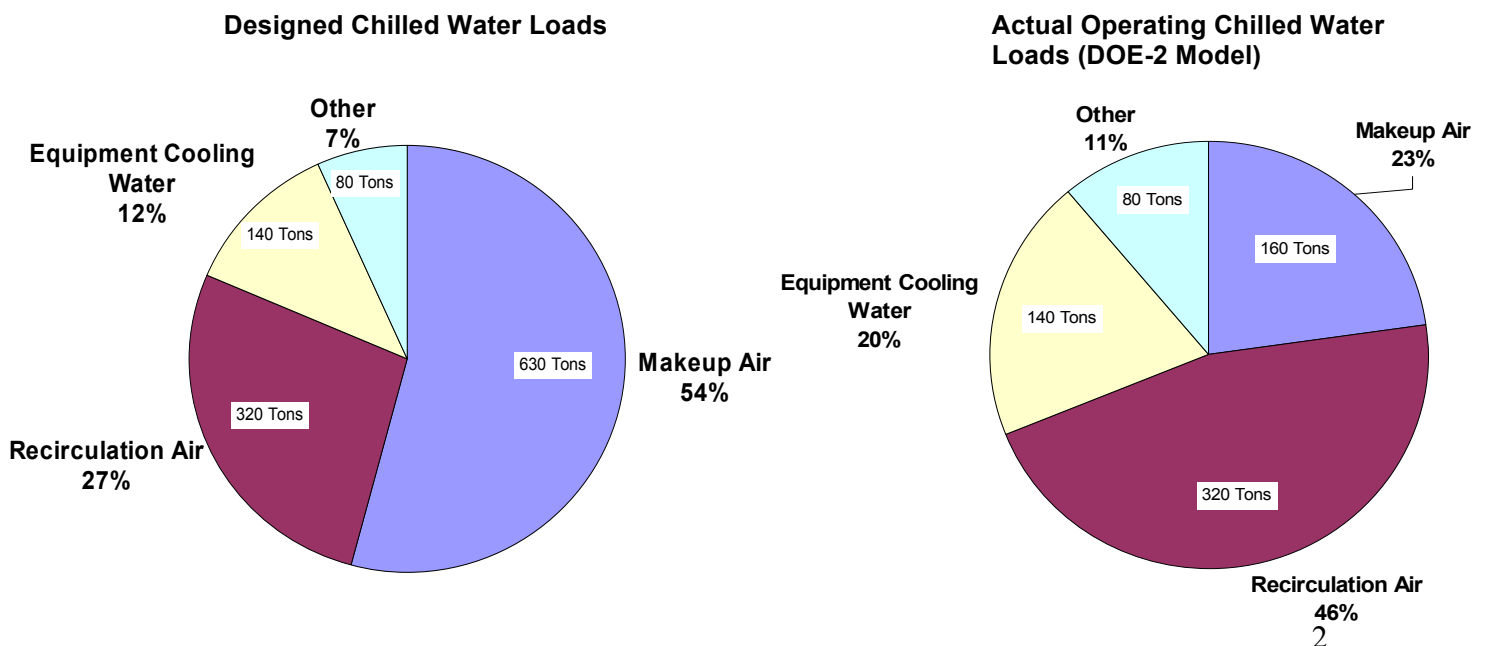

Chiller efficiency is directly impacted by the chilled water supply temperature – chillers operate most efficiently when the temperature lift (the difference in temperature between the evaporator and the condenser) is minimized. The magnitude of the lift is proportional to the difference between the chilled water supply temperature and condenser water supply temperature. The lift is reduced if either the condenser water supply temperature is reduced or if the chilled water supply temperature is increased. Therefore, if the medium temperature water loads can be served by a chiller operating at the required medium supply temperature, the chiller energy required will be reduced significantly over a low temperature chiller with mixing loop or heat-exchanger.

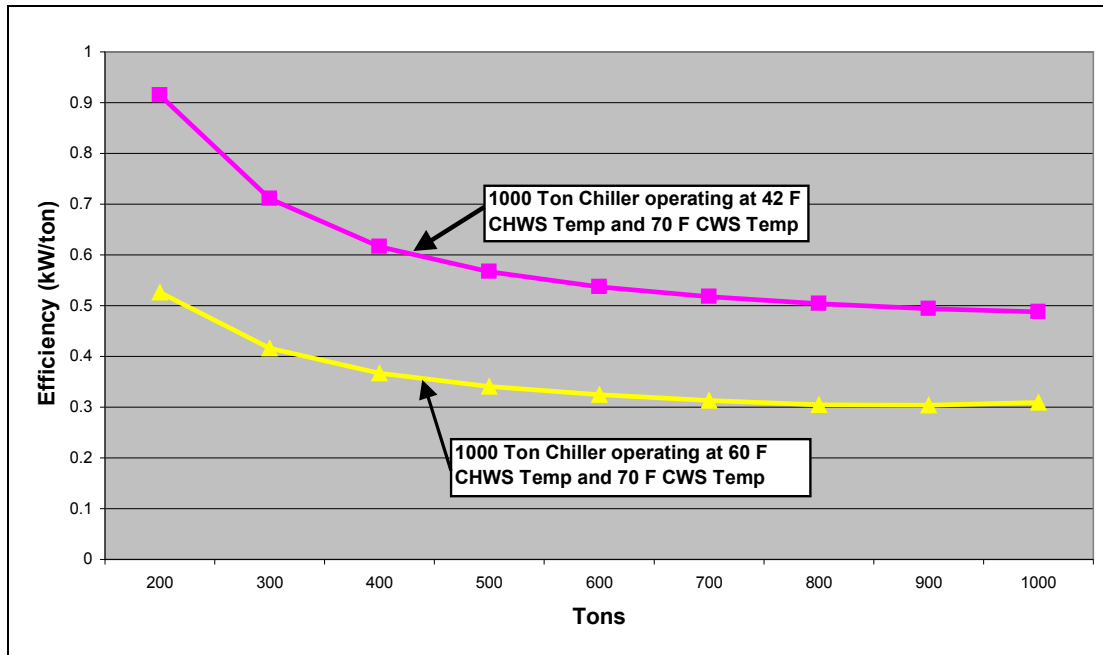

Figure 2. Comparison of Low Temperature and Medium Temperature Water-cooled Chillers

Figure 1 compares the chiller operating curves of the same chiller at two different chilled water supply temperatures with a constant condenser water supply temperature. The entire operating range of the chiller with 60°F chilled water temperature is vastly more efficient than the chiller operating at 42°F as shown in Figure 2. The energy savings of the chiller operating at 60°F are 40% over the entire load range. In a well-configured and controlled system, there will also be condenser pump and tower savings (both first-cost and operating cost), since the more-efficient chiller has less total heat to reject.

A common first-cost challenge is economically providing redundancy. While the savings possible from implementing a medium temperature chiller loop can usually justify additional backup equipment, careful plant layout and design can allow the same chiller to provide backup to the low temperature and the medium temperature loop – providing redundancy at about the same cost as a standard single temperature plant. The redundant chiller should be sized and piped to provide either low temperature or medium temperature water (see Figure 3) as required. Selecting the backup chiller without a variable frequency drive (VFD) can help to lower the initial cost. However, the decision

to select a variable frequency driven chiller as the backup should be based on the anticipated runtime of the chiller, and whether or not the chiller needs to be rotated into the normal operating schedule.

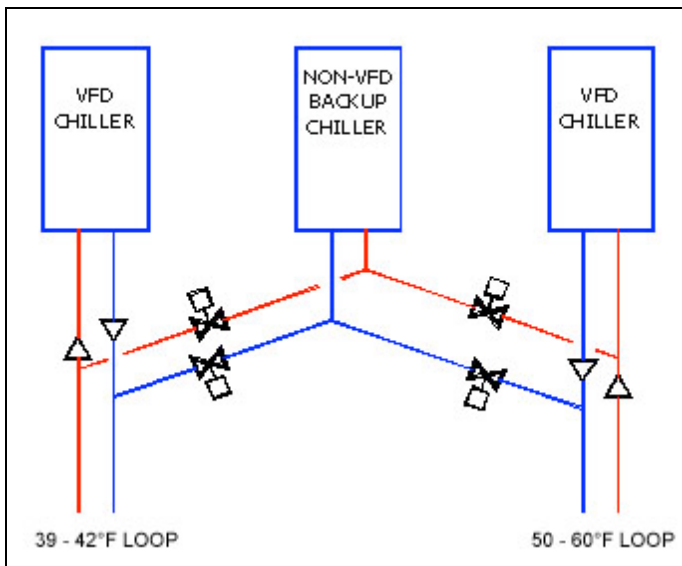

Figure 3. Configuration of Chillers for a Dual Temperature Chilled Water Loop System

A medium temperature loop also greatly expands the potential for free cooling, which is when the cooling tower is utilized to produce chilled water. Cooling towers sized for an approach temperature of 5 to 8°F can be utilized to produce chilled water at 55°F for much of the year, particularly at night in moderate and dry climate zones such as in California and Arizona. There is better system redundancy in a dual temperature chilled water loop system as compared to a low temperature chilled water loop system that provides cooling for sensible and process loads. Failures can be caused by controls of the temperature loops, automated valves and fouling of the heat exchangers, which exist in greater abundance in a low temperature chilled water loop system.

Real World Experiences (Benchmarking Findings / Case Studies)

A dual temperature chilled water loop system was measured at a 4,200 sf cleanroom facility (referred to as Facility G) in a recent benchmarking study. The medium temperature loop was providing 1,300 tons of cooling to sensible cooling air handler coils and process cooling at a water supply temperature of 48°F. The low temperature loop was providing 1,200 tons of cooling to the makeup air handlers at a water supply temperature of 42°F.

The medium temperature water-cooled chillers and the low temperature water-cooled chillers had an operating efficiency of 0.57 kW/ton and 0.66 kW/ton, respectively. The medium temperature chillers were running at about 14% better in efficiency due to a chilled water temperature difference of only 6°F.

In a pilot project for a multiple cleanroom building campus, implementation of a dual temperature chilled water system was analyzed. The cleanroom facility required 3,900 tons of cooling: 2,370 tons of makeup air cooling, and 1,530 tons of sensible and process cooling. By providing 42°F temperature water for low temperature use and 55°F for medium temperature use, approximately \$1,000,000 would be saved per year (electricity rate of \$0.13/kWh). The cost of implementing this was \$2,000,000 with a payback of only 2 years.

Related Best Practices

Control of Chilled Water Systems
Cooling Tower & Condenser Water
Optimization

Variable Speed Chillers
Free Cooling

References

- 1) <http://hightech.lbl.gov/cleanrooms.html>

Resources

- <http://hightech.lbl.gov/>